



We can provide interpreters for a variety of languages, information in larger print or other formats (e.g. audio) - please call us on 01932 723553.

To use the Text Relay service, prefix all numbers with 18802.

اگر نیاز به ترجمہ دارید، لطفاً با شماره 01932 723553 تماس بگیرید۔

ने उगाठुं उरनमे दी लेउ वै उं विरथा वरवे इस नंघर उे बेन वरवे: 01932 723553

اگر آپ اس کا اردو زبان میں ترجمہ چاہتے ہیں، تو براہ کرم اس فون نمبر 01932 723553 پر رابطہ کریں

Se precisa de uma tradução por favor contacte: 01932 723553

আপনার অনুবাদের দরকার হলে এখানে যোগাযোগ করুন : 01932 723553

यदि आपको अनुवाद की ज़रूरत है तो कृपया इस नंबर पर फोन करें: 01932 723553

Jeżeli chcemy, aby te informacje w innym języku, proszę zadzwonić 01932 723553

Ashford Hospital
London Road
Ashford, Middlesex
TW15 3AA
Tel: **01784 884488**

St. Peter's Hospital
Guildford Road
Chertsey, Surrey
KT16 0PZ.
Tel: **01932 872000**

Website: www.ashfordstpeters.nhs.uk

GETTING ABOUT WITH YOUR WHEELCHAIR

Occupational Therapy Department

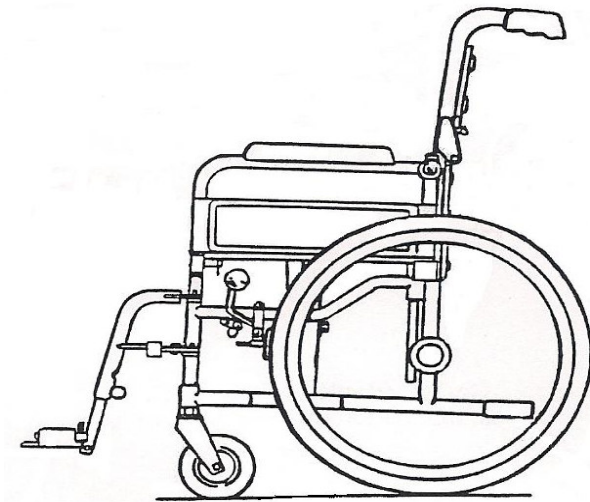

Further Information

We endeavour to provide an excellent service at all times, but should you have any concerns please, in the first instance, raise these with the Matron, Senior Nurse or Manager on duty. If they cannot resolve your concern, please contact our Patient Advice and Liaison Service (PALS) on 01932 723553 or email pals@asph.nhs.uk. If you still remain concerned please contact our Complaints Manager on 01932 722612 or email complaints@asph.nhs.uk

**Author: Stephanie Mansell, Senior Physiotherapist & Mark Guthrie, Occupational Therapist
Department: Occupational Therapy**

- You must not dispose of the equipment and contact us as soon as you have no further use for it.
- You must keep it clean and in good working order.
- It is for your use and not to be used for anything other than its intended use.
- You are not to alter or have attachments fitted to the equipment without our agreement.

You must notify us if:

- The chair is involved in an accident.
- Damaged or lost.
- You have changed your address.
- You have decided to emigrate
- No longer have a use for the equipment.

In addition if you decide to take the equipment abroad and it is damaged, you are responsible for the cost of any damage, loss or repairs whilst outside the United Kingdom.

Information for users of wheelchairs on loan from the Occupational Therapy Department

PARTS OF YOUR WHEELCHAIR

SELF – PROPELLING

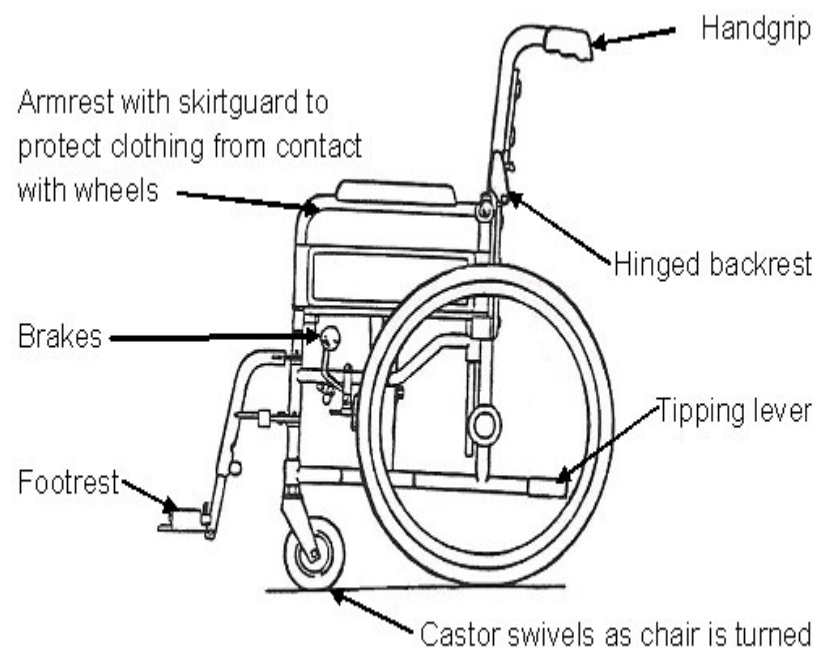

ARMRESTS

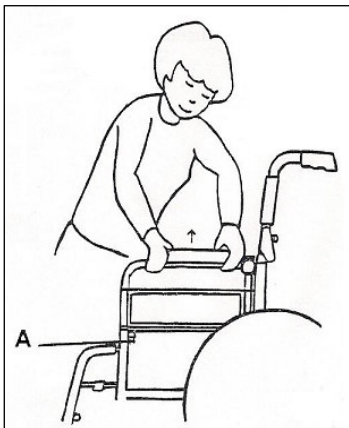

Most wheelchairs have fitted detachable armrests. This is useful for fitting a tray or for a sideways transfer.

To remove: Pull lever 'A' and lift armrest up out of sockets

To replace: Place front armrest tube into frame first, then place rear tube into socket. Check to make sure lever 'A' has fully engaged

STUMP BOARDS

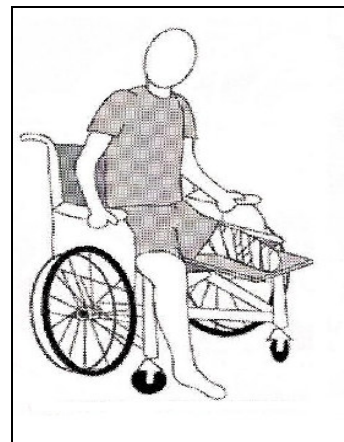

If you have a lower leg amputation you may be provided with a stump board. Please ensure that you use it at all times whilst seated as it will help maintain comfort and a proper positioning of the stump, and will also prevent pain and swelling. The stump board can be removed the same way as the foot rest.

BACKRESTS

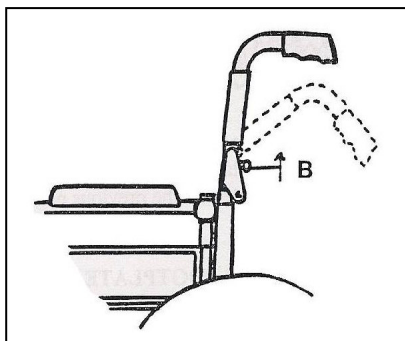

Most wheelchairs have a folding or hinged backrest which makes the chair compact for storage or stowing in a car boot.

To fold: Stand behind the chair, lift lever 'B' on each push handle, and pull handles backwards.

To unfold: Raise push handles, push lever 'B' down firmly to locate inner tubes into sockets of the chair frame

TOOLS

To carry out repairs to your wheelchair, you will need the following equipment:

- | | |
|--------------------|----------------------------|
| Pump | Small adjustable spanner |
| Spray lubricant | Small Phillips screwdriver |
| Cleaning materials | Puncture repair kit |
| Tyre levers | |

CONDITIONS OF LOAN

The wheelchair is the property of the local health authority and is loaned to you on the conditions shown below:

- The equipment must be returned or given up for repair as soon as you are asked.

GOING UP AND DOWN KERBS WITH AN ATTENDANT

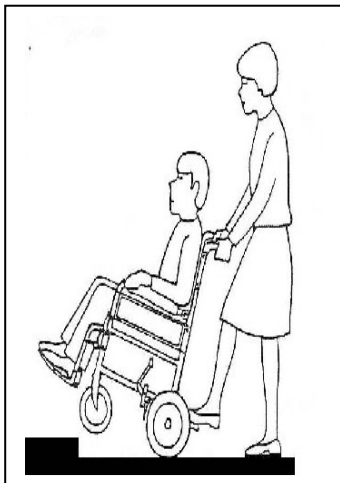

Check to see if you can locate a dropped kerb or ramp nearby, if you are not able to find one then position the chair square to the kerb.

Grip the handles firmly, place one foot on the tipping lever. Push down and balance the chair on its rear wheels.

If going down gently lower with the wheels against the kerb, whilst supporting some of the weight of the chair.

If going up the kerb, balance the chair on its rear wheels until they touch the kerb, then gently lift the chair on to the pavement.

TO TRANSFER

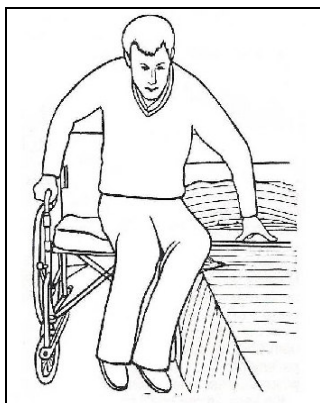

As your wheelchair has detachable arms, removing the appropriate side will help transferring from the side of the chair. It may help if you have a smooth board (banana board) to slide along. Position your wheelchair alongside the seat, bed, toilet etc. and apply the brakes. Remove the armrest and lift the footrests back out of the way. Your foot should be on the ground, **not on the footplate**.

If you are able to pivot transfer, use your leg to pivot on the seat, bed, toilet etc. If using a sliding board, slide it from seat to wheelchair, bend it slightly upwards and slide across on to seat or bed.

BRAKES

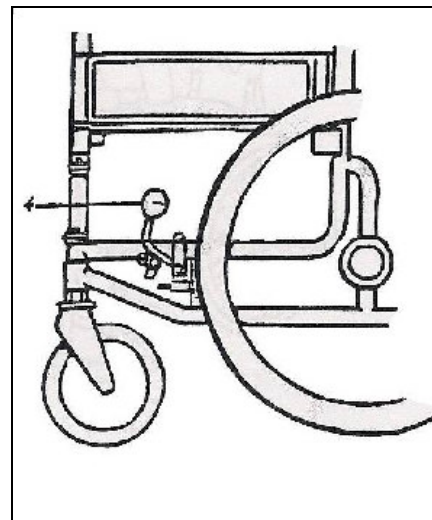

Brakes must always be applied when transferring into and out of the wheelchair.

This is to prevent it from rolling away when you are seating yourself or using the armrests to raise yourself out of the chair.

Brakes should also be applied when folding and opening the chair.

To apply, push the handle forward.

FOOTRESTS

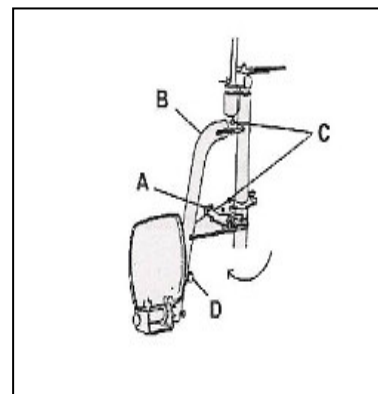

Footrests can be removed to make the chair lighter to lift, or swung out of the way to ease getting into the chair.

Alternatively the footplates 'D' can be raised out of the way.

To detach: Push plate 'A' towards the back of the chair to release the catch, swing the footrest outwards, and to remove grasp at point 'B' and lift

To attach: Match the holes on the footrests with the pivot points on the chair 'C' and swing footrests inwards until catch 'A' engages

TO ADJUST THE HEIGHT OF THE FOOT PLATE

The footplate height can be adjusted for your comfort, and the safest position is usually with your thighs horizontal and the hips and thighs at right angles.

To move the foot plate loosen the nut (shown above as 'D') with a spanner, adjust for comfort then re-tighten the nut.

Remember: Never use the footplate to enter or leave the wheelchair as this can cause the chair to tip over.

PLACING WHEELCHAIR IN TO THE BOOT OF A CAR

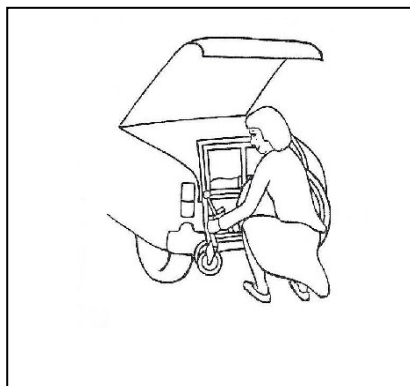

Apply the brakes.
Remove all accessories – straps, cushions etc. and removable parts.
Fold chair, including backrest and position chair parallel to boot.
Bend your knees, grasp the frame and lift into the boot.

TO OPEN YOUR WHEELCHAIR

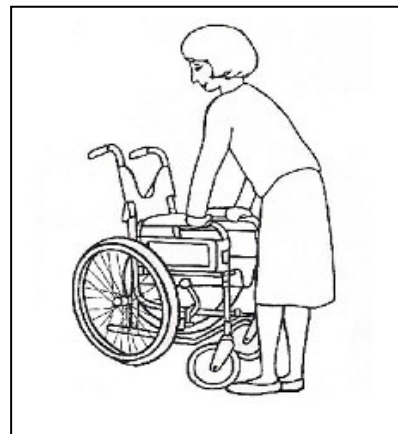

Push the armrests as far apart as possible.
Tilting the chair to balance on its side wheels as you do so may help.
Push down on the side edges on the seat, keeping your fingers facing inwards.
Never put your fingers between the frame and seat.

TO CLOSE YOUR WHEELCHAIR

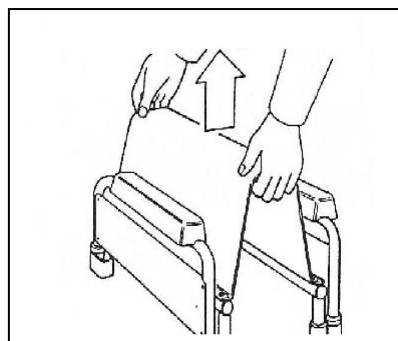

Turn footplates upright and footrests out to the sides or remove completely.
Grasp the middle of the seat canvas at the front and back, and pull upwards until chair is fully closed.